

FEATURES

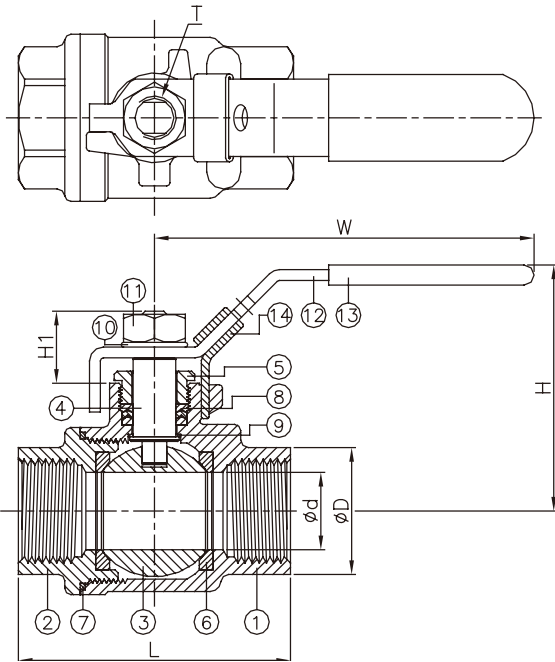

- Full port, 1/4"~3" (DN8~DN80)
- W.P. : 1000 WOG (PN63)
- W.T. : -20°C~200°C (-4°F~392°F)
- Investment casting
- Blow-out proof stem
- Locking device
- Tapped & drilled mounting pad (option)
- TA-Luft approved (option)
- Length conform to DIN 3202/4-M3-2006SM3 (option)
- Thread type : ASME B1.20.1 (NPT)
DIN2999 & BS21
ISO7/1 & EN10226



ITEM	PARTS	MATERIAL	
1	BODY	ASTM A351-CF8M	ASTM A216-WCB
2	CAP		
3	BALL	ASTM A351-CF8M	
4	STEM	ASTM A276-316	
5	GLAND	AISI 304	
6	SEAT	PTFE / RTFE	
7	SEAL	PTFE	
8	PACKING		
9	THRUST WASHER	AISI 304	
10	SPRING WASHER		
11	NUT	AISI 304	
12	HANDLE	STAINLESS STEEL	
13	HANDLE SLEEVE	PVC	
14	LOCKING DEVICE	AISI 304	

BSPP	d	D	L	H	HI	T	W	Torque (in-lb)	Weight (lb)
1/4"	0.46	0.75	2	2.3	0.71	3/8"-24UNF	3.94	31	0.5
3/8"	0.49	0.89	2	2.3	0.71	3/8"-24UNF	3.94	35.4	0.5
1/2"	0.59	1.02	2.28	2.3	0.73	3/8"-24UNF	3.94	48.7	0.7
3/4"	0.79	1.26	2.58	2.5	0.89	7/16"-20UNF	4.92	66.4	1
1"	0.98	1.5	3.1	3.07	0.98	7/16"-20UNF	5.87	97.4	1.7
1-1/4"	1.26	1.89	3.54	3.27	1.02	7/16"-20UNF	5.87	132.8	2.5
1-1/2"	1.5	2.16	4.13	4.02	1.18	1/2"-20UNF	7.48	177	3.9
2"	1.97	2.64	4.88	4.25	1.18	1/2"-20UNF	7.48	354	5.9
2-1/2"	2.48	3.35	5.75	5.43	1.57	3/4"-10UNF	9.84	531	12.4
3"	2.99	3.94	6.46	5.75	1.57	3/4"-10UNF	9.84	752.3	16.5